

2952

ISTRUZIONI DI MONTAGGIO / FITTING INSTRUCTIONS / INSTRUCCIONES PARA SU MONTAJE / MONTAGEANWEISUNGEN / INSTRUCTIONS DE MONTAGE / MONTAGE INSTRUCTIES / SZERELÉSI UTASÍTÁS / INSTRUKCJA MONTAZU / NAVŮDILA O MONTÁŽI.

1

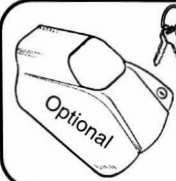

ATTENZIONE: Punto da eseguire solo con l'optional.
ATTENTION: To follow only when installing the optional cover with key.
ATTENTION: À suivre uniquement pour le montage des caches avec serrures.
ACHTUNG: Zu beachten nur bei Montage der Zier-abdeckung mit Schloesser.
ATENCION: Seguir únicamente para el montaje de las cerraduras con llave.
LET OP: Alleen voor installeren van de optionele top met sleutel.

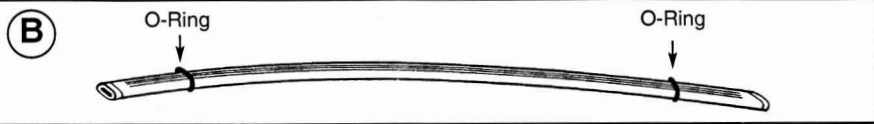
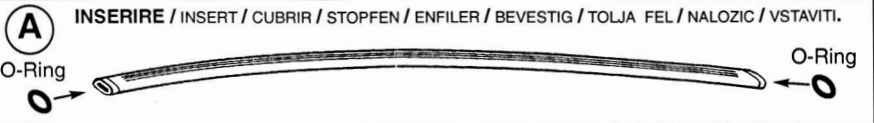

GIRARE LE BARRE NEL VERSO GIUSTO.

SET BARS IN THE CORRECT POSITION AS SHOWN BELOW.
 POSITIONNER LES BARRÉS CORRECTÉMENT COMME INDIQUÉ CI-DESSOUS.
 BARREN RICHTIG POSITIONNIËREN, WIE UNTER GEZEICHNET.
 COLOCAR LAS BARRAS CORRECTAMENTE COMO INDICADO ABAJO.
 PLAATS DE DRAGER IN DE JUISTE POSITIE, ZOALS HIERONDER AANGEGEVEN.

2

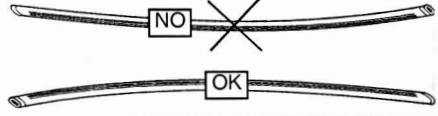

3

INSERIRE / INSERT / CUBRIR / STOPFEN / ENFILER / BEVESTIG / TOLJA FEL / NALOZIC / VSTAVITI.

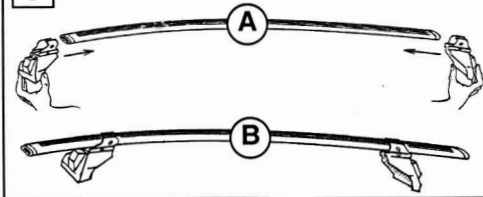

4

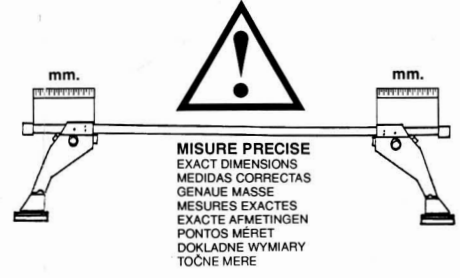
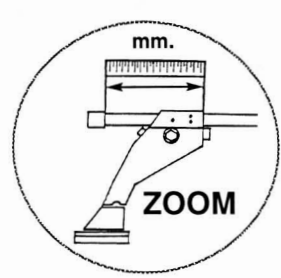

MISURE PRECISE
 EXACT DIMENSIONS
 MEDIDAS CORRECTAS
 GENAUË MASSE
 MESURES EXACTES
 EXACTE AFMETINGEN
 PONTOS MÉRÉT
 DOKŁADNE WYMIARY
 TOČNĚ MĚRE

MODELLI AUTO / CARS / COCHES / WAGEN / VOITURES / AUTO / AUTŮ TIPUS / MODELI AVTOMOBILŮV.		
	ANTERIORE / FRONT / DELANTERO / VORDERE	AVANT / VOORSTE G. / ELSŐ RÜD / PRZOD / SPREDAJ
NUOVA SUZUKI SWIFT 5P. (05->)	123 mm.	142 mm

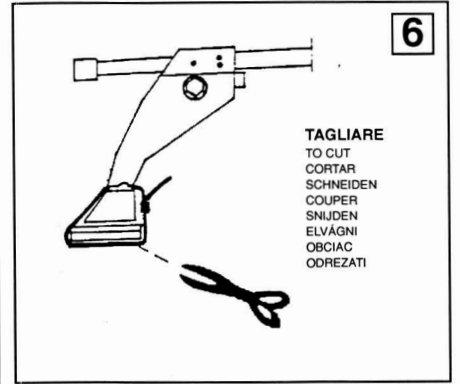
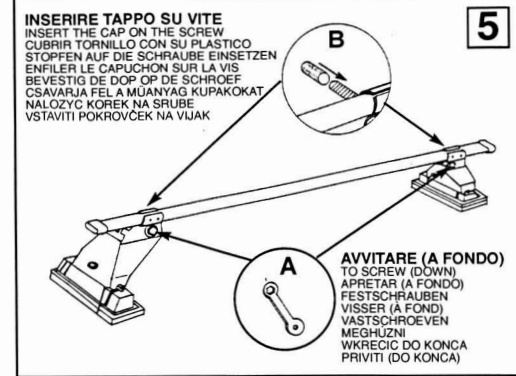

7



MODELLI AUTO / CARS / COCHES /
 WAGEN / VOITURES / AUTO / AUTŮ TIPUS /
 MODELI AVTOMOBILŮV.

ANTERIORE / FRONT / DELANTERO / VORDERE / AVANT / VOORSTE G. / ELSŐ RÜD / PRZOD / SPREDAJ	POSTERIORE / REAR / TRASERO / HINTERE / ARRIERE / ACHTERSTE G. / HATSÓ RÜD / TYL / ZADAJ
N°	N°
2	2

NUOVA SUZUKI SWIFT 5P. (05->)

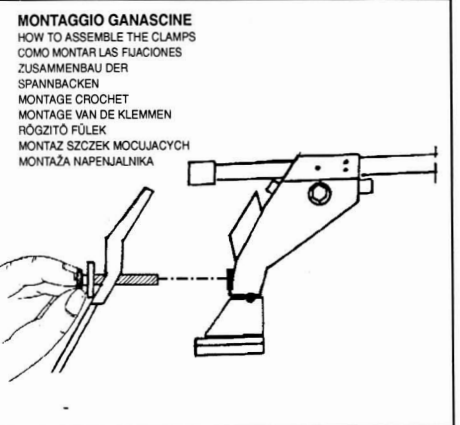

8



PULIRE IL TETTO
 CLEAN THE ROOF
 LIMPIAR EL TECHO
 DACH REINIGEN
 NETTOYER LE TOIT
 DAK SCHOONMAKEN
 TISZÍTSA MEG A TETŐT
 WYCZYSCIC DACH
 OCISITITI STREHO

9

CENTRARE IL P. TUTTO SUL TETTO
 CENTRE THE UNIVERSAL BAR CARRIER ON THE ROOF
 CENTRAR EL PORTAEQUIPAJES SOBRE EL TECHO
 LASTENTRÄGER AUF DEM DACH ZENTRIEREN
 CENTRER LE TOIT AVEC LE PORTE-TOUT
 PLAATS DE UNIVERSELE DRAGER IN HET MIDDEN VAN HET DAK
 HELYEZZE KÖZÉPRE A RUDAKAT
 WYSRODKOWAC BAGAZNIK NA DACHU
 CENTRIRATI PRTLJAŽNIK NA STREHO

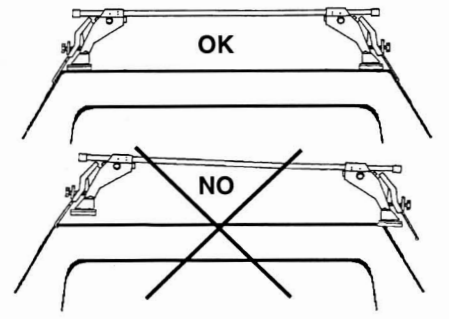

MODELLI CON PREDISPOSIZIONE DELLA CASA AUTO:

CARS WITH PRE-EXISTING FIXING POINT FROM MANUFACTURER
 MODELOS CON PREDISPOSICION DEL FABRICANTE
 AUTOS MIT VOM HERSTELLER VORGESEHENE BEFESTIGUNGSPUNKTE
 VOITURES AVEC POINTS DE FIXAGE PREVUS PAR LE CONSTRUCTEUR
 AUTO'S MET DOOR DE FABRIKANT VOORZIENE MONTAGEPUNTEN
 FELHÉLYEZÉS GYÁRTÓ ÁLTAL KIJELÖLT PONTRA
 SAMOCHODY Z PRZEWIDZIANYMI PUNKTAMI UMOCOWANIA
 MODELI Z PREDVIDENIM LEŽIŠČEM S STRANI PROIZVAJALCA

10

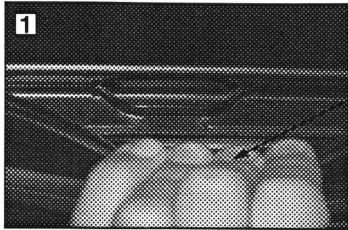

1
SCALZARE LA GUARNIZIONE
 REMOVE THE GASKET
 QUITE LA MOLDURA
 DICHTUNG HERAUSZIEHEN
 ÖTER LA GUARNITURE
 PAKKUNG LOSMAKEN
 KIHAJTANI A TÖMITŐGUMIT
 WYCIĄGNAC USZCZELKĘ
 ODMAKNITI TESNILO

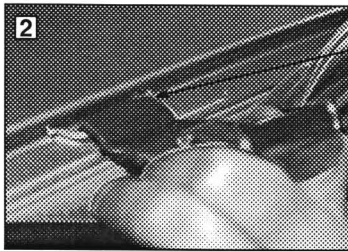

2
INSERIRE
 INSERT
 CUBRIIR
 STOPFEN
 ENFILER
 BEVESTIG
 TOLJA FEL
 NALOZIC
 VSTAVITI

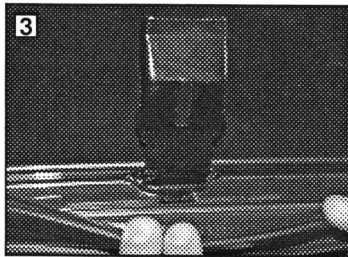

X4

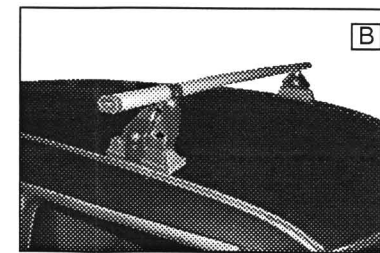
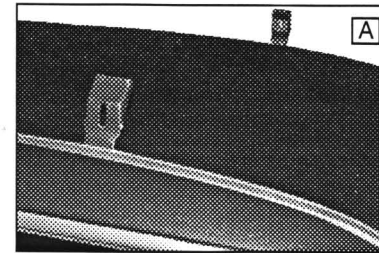
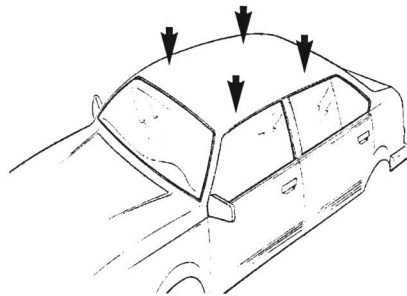

11

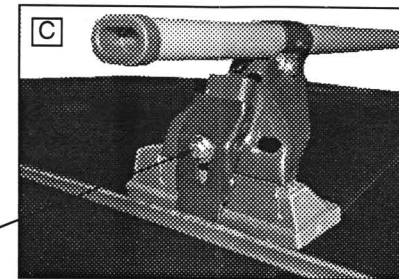

AVVITARE
 TO SCREW
 APRETAR
 FESTSCHRAUBEN
 VISSER
 VASTSCHROEVEN
 MEGHÚZNI
 WKREĆC
 PRIVITI

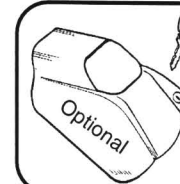

ATTENZIONE: Punto da eseguire solo con l'optional.
ATTENTION: To follow only when installing the optional cover with key.
ATTENTION: À suivre uniquement pour le montage des caches avec serrures.
ACHTUNG: Zu beachten nur bei Montage der Zier- abdeckung mit Schloesser.
ATENCION: Seguir únicamente para el montaje de las cerraduras con llave.
LET OP: Alleen voor installeren van de optionele top met sleutel.

12

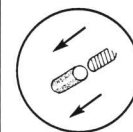

A **TOGLIERE TAPPO SU VITE**
 REMOVE THE SCREW CAP
 ENLEVER LE CAPUCHON DE LA VIS
 DIE SCHRAUBE-ABDECKUNG ABNEHMEN
 SACAR EL TAPON DEL TORNILLO
 VERWIJDER DE SCHROEFDOP

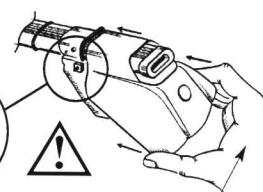

B **INSERIRE**
 INSERT
 CUBRIIR
 STOPFEN
 ENFILER
 BEVESTIG
 TOLJA FEL
 NALOZIC
 VSTAVITI

13

INSERIRE / INSERT / CUBRIIR / STOPFEN / ENFILER / BEVESTIG / TOLJA FEL / NALOZIC / VSTAVITI.

