

8

OPTIONAL

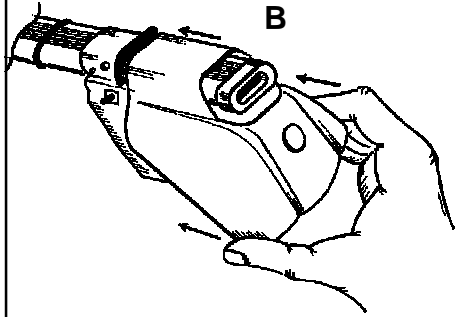
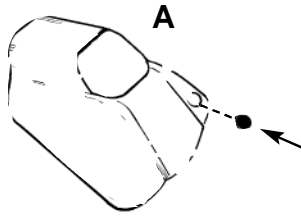

INSERIRE
 INSERT
 CUBRIR
 STOPFEN
 ENFILER
 BEVESTIG
 TOLJA FEL
 NALOZIC
 VSTAVITI

9

O-Ring

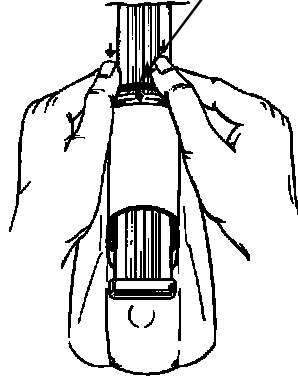

87co

ISTRUZIONI DI MONTAGGIO - FITTING INSTRUCTIONS - INSTRUCCIONES PARA SU MONTAJE -
 MONTAGEANWEISUNGEN - INSTRUCTIONS DE MONTAGE - MONTAGE INSTRUCTIES -
 SZERELÉSI UTASÍTÁS - INSTRUKCJA MONTAŻU - NAVODILA O MONTAŽI

“LOGICO”

1

**MISURE PRECISE**

EXACT DIMENSIONS
 MEDIDAS CORRECTAS
 GENAUUE MASSE
 MESURES EXACTES
 EXACTE AFMETINGEN
 PONTOS MÉRET
 DOKLADNE WYMIARY
 TO»NE MERE

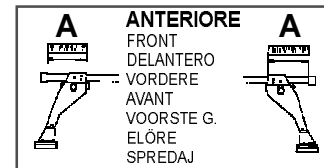
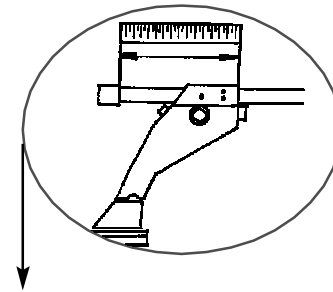
**ANTERIORE**

FRONT
 DELANTERO
 VORDERE
 AVANT
 VOORSTE G.
 ELŐRE
 SPREDAJ

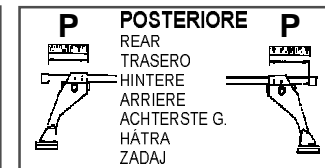
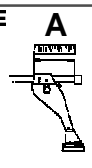
**POSTERIORE**

REAR
 TRASERO
 HINTERE
 ARRIERE
 ACHTERSTE G.
 HÁTRA
 ZADAJ



A
ANTERIORE
 FRONT
 DELANTERO
 VORDERE
 AVANT
 VOORSTE G.
 ELSŐ RÚD
 PRZOD

P
POSTERIORE
 REAR
 TRASERO
 HINTERE
 ARRIERE
 ACHTERSTE G.
 HÁTSÓ RÚD
 TYL

SKODA OCTAVIA (2005-2012)

138 mm.

145 mm.

SKODA OCTAVIA (2013-)

100 mm.

116 mm.

SKODA RAPID (2012-)

98 mm.

100 mm.

SEAT TOLEDO (2013-)

98 mm.

100 mm.

2

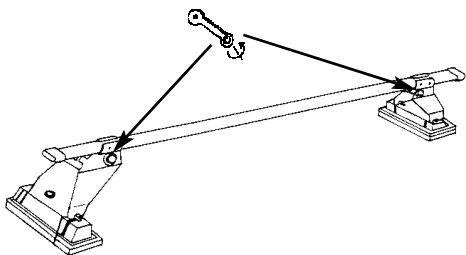
**AVVITARE (A FONDO)**

TO SCREW (DOWN)
 APRETAR (A FONDO)
 FESTSCHRAUBEN
 VISSER (À FOND)
 VASTSCHROEVEN
 MEGHÚZNI
 WKRECIC DO KONCA
 PRIVITI (DO KONCA)

3

TAGLIARE

TO CUT
 CORTAR
 SCHNEIDEN
 COUPER
 SNIJDEN
 ELVÁGNI
 OBCIAC
 ODREZATI

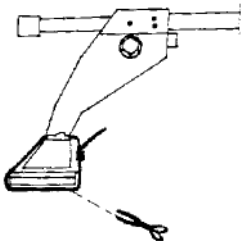

4

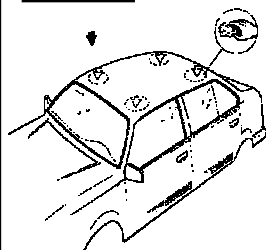
**PULIRE IL TETTO**

CLEAN THE ROOF
 LIMPIAR EL TECHO
 DACH REINIGEN
 NETTOYER LE TOIT
 DAK SCHOONMAKEN
 TISZTITSA MEG A TETŐT
 WYCZYSCIC DACH
 O»STITI STREHO

5

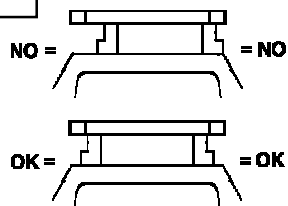
**CENTRARE IL P. TUTTO SUL TETTO**

CENTRE THE UNIVERSAL BAR
 CARRIER ON THE ROOF
 CENTRAR EL PORTAEQUIPAJES
 SOBRE EL TECHO
 LASTENTRÄGER AUF DEM DACH
 ZENTRIEREN
 CENTRER LE TOIT AVEC LE
 PORTE-TOUIT
 PLAATS DE UNIVERSELE DRAGER
 IN HET MIDDEN VAN HET DAK
 HELYEZZE KÖZÉPRE A RUDAKAT
 WYSRODKOWAC BAGAŻNIK NA DACHU
 CENTRIRATI PRTLJA»ENIK NA STREHO

6

MODELLI AUTO

CARS
 COCHES
 WAGEN
 VOITURES
 AUTO
 AUTÓ TIPUS
 MODELI AVTOMOBILOV

MONTAGGIO GANASCINE

HOW TO ASSEMBLE THE CLAMPS
 COMO MONTAR LAS FIJACIONES
 ZUSAMMENBAU DER
 SPANNBACKEN
 MONTAGE CROCHET
 MONTAGE VAN DE KLEMMEN
 RÖGZITŐ FÜLEK
 MONTAZ SZCZEK MOCUJACYCH
 MONTA»EA NAPENJALNIKA

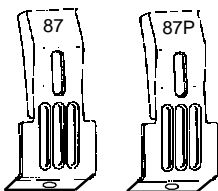

SKODA OCTAVIA BERLINA (05->) 87 87P

ANTERIORE POSTERIORE

FRONT DELANTERO VORDERE AVANT VOORSTE G. ELSŐ RÜD PRZOD SPREDAJ
 REAR TRASERO HINTERE ARRIERE ACHTERSTE G. HÁTSÓ RÜD TYL ZADAJ

N°

N°

7

MODELLI CON PREDISPOSIZIONE DELLA CASA AUTO:

CARS WITH PRE-EXISTING FIXING POINT FROM MANUFACTURER
 MODELOS CON PREDISPOSICION DEL FABRICANTE
 AUTOS MIT VOM HERSTELLER VORGESEHENE BEFESTIGUNGSPUNKTE
 VOITURES AVEC POINTS DE FIXAGE PREVUS PAR LE CONSTRUCTEUR
 AUTO'S MET DOOR DE FABRIKANT VOORZIENE MONTAGEPUNTEN
 FELHELYEZÉS GYÁRTÓ ÁLTAL KIJELÖLT PONTRA
 SAMOCHODY Z PRZEWIDZIANYMI PUNKTAMI UMOCOWANIA
 MODELI Z PREDVIDENIM LE»ELI»EM S STRANI PROIZVAJALCA

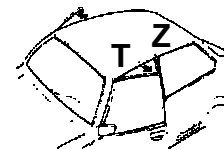
**ANTERIORE**

FRONT
 DELANTERO
 VORDERE
 AVANT
 VOORSTE G.
 ELSŐ RÜD
 PRZOD
 SPREDAJ

POSTERIORE

REAR
 TRASERO
 HINTERE
 ARRIERE
 ACHTERSTE G.
 HÁTSÓ RÜD
 TYL
 ZADAJ

MODELLI AUTO

SKODA OCTAVIA (2005-2012)

T

Z

SKODA OCTAVIA (2013-)

T

Z

SKODA RAPID (2012-)

T

Z

SEAT TOLEDO (2013-)

T

Z

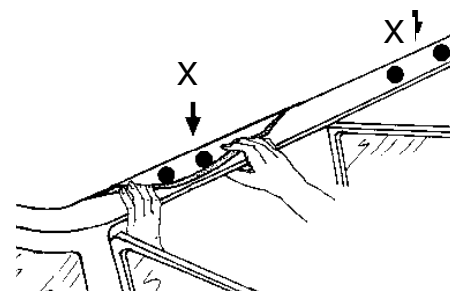
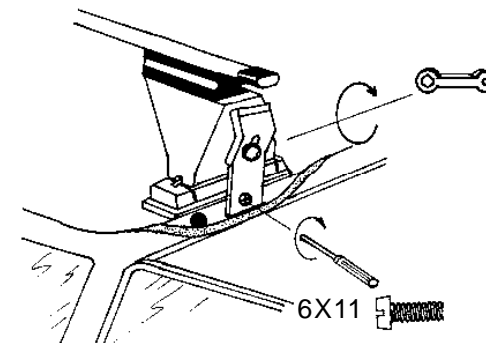

(IT) AVVITARE
 (GB) TO SCREW
 (E) APRETAR
 (D) FESTSCHRAUBEN
 (F) VISSER
 (NL) VASTSCHROEVEN
 (P) APERTAR
 (H) MEGHÚZNI
 (L) WKRECIC
 (SLO) PRIVITI
 (HR) PRI»VRSTITI