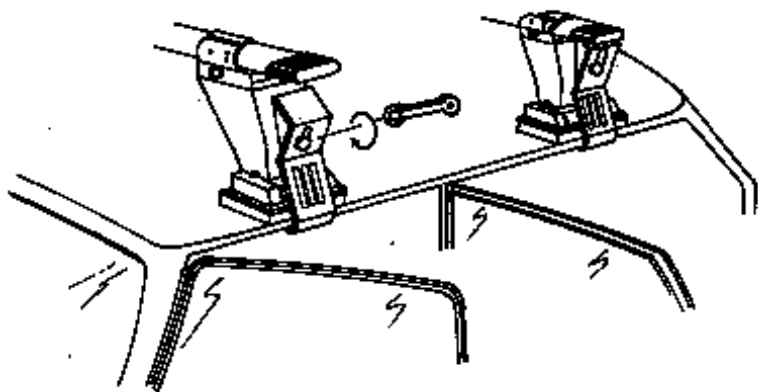
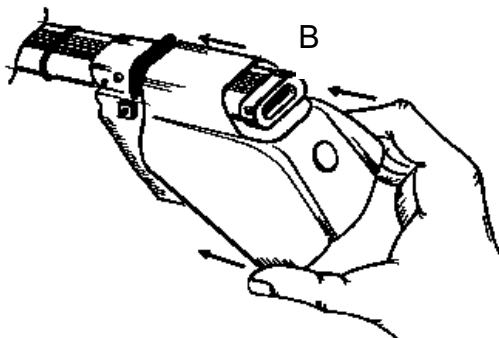
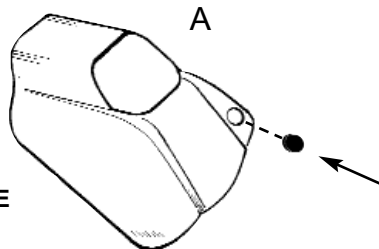
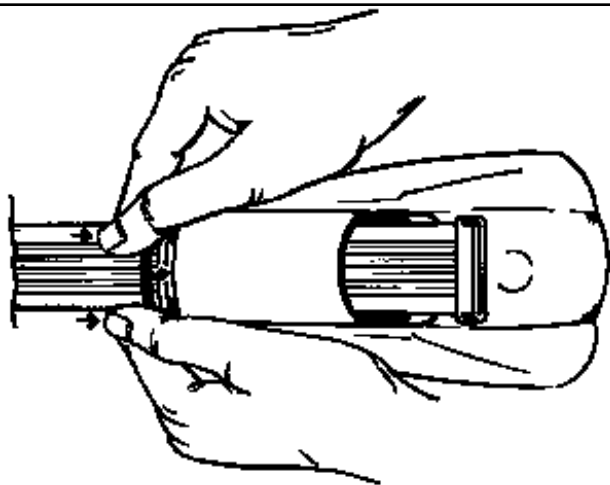

8**AVVITARE**

TO SCREW
 APRETAR
 FESTSCHRAUBEN
 VISSER
 VASTSCHROEVEN
 MEGHÚZNI
 WKRECIC
 PRIVITI

**9****OPTIONAL****INSERIRE**

INSERT
 CUBRIR
 STOPFEN
 ENFILER
 BEVESTIG
 TOLJA FEL
 NALOZIC
 VSTAVITI

**10****70
CO**

**ISTRUZIONI DI MONTAGGIO - FITTING INSTRUCTIONS - INSTRUCCIONES PARA SU MONTAJE -
 MONTAGEANWEISUNGEN - INSTRUCTIONS DE MONTAGE - MONTAGE INSTRUCTIES - SZERELÉSI
 UTASITÁS - INSTRUKCJA MONTAŻU - NAVODILA O MONTAŽI**

“LOGICO”**1****MISURE PRECISE**

EXACT DIMENSIONS
 MEDIDAS CORRECTAS
 GENAUE MASSE
 MESURES EXACTES
 EXACTE AFMETINGEN
 PONTOS MÉRET
 DOKLADNE WYMIARY
 TO»NE MERE

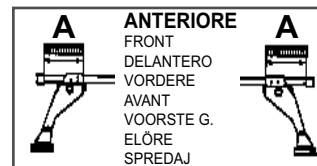
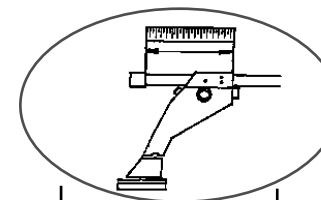
**ANTERIORE**

FRONT
 DELANTERO
 VORDERE
 AVANT
 VOORSTE G.
 ELÖRE
 SPREDAJ

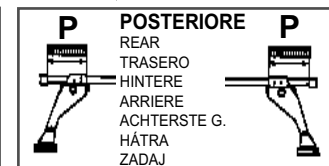
**POSTERIORE**

REAR
 TRASERO
 HINTERE
 ARRIERE
 ACHTERSTE G.
 HÁTRA
 ZADAJ



A
ANTERIORE
 FRONT
 DELANTERO
 VORDERE
 AVANT
 VOORSTE G.
 ELÖRE
 SPREDAJ

P
POSTERIORE
 REAR
 TRASERO
 HINTERE
 ARRIERE
 ACHTERSTE G.
 HÁTRA
 ZADAJ

KIA RIO I 5P. (00-05)
KIA RIO II 5P. (05-11)
NISSAN NOTE (06-13)

108 mm.
92 mm.
164 mm.
117 mm.
98 mm.
160 mm.

2

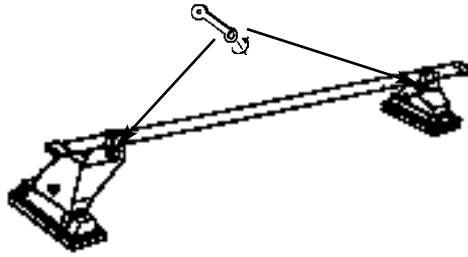
**AVVITARE (A FONDO)**

TO SCREW (DOWN)
 APRETAR (A FONDO)
 FESTSCHRAUBEN
 VISSER (À FOND)
 VASTSCHROEVEN
 MEGHÚZNI
 WKRECIC DO KONCA
 PRIVITI (DO KONCA)

3

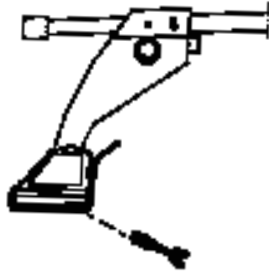
**TAGLIARE**

TO CUT
 CORTAR
 SCHNEIDEN
 COUPER
 SNIJDEN
 ELVÁGNI
 OBCIAC
 ODREZATI

4

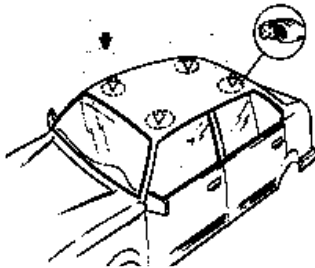
**PULIRE IL TETTO**

CLEAN THE ROOF
 LIMPIAR EL TECHO
 DACH REINIGEN
 NETTOYER LE TOIT
 DAK SCHOONMAKEN
 TISZTÍTSA MEG A TETŐT
 WYCZYSCIC DACH
 O»ISTITI STREHO

5

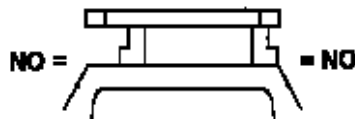
**CENTRARE IL P. TUTTO SUL TETTO**

CENTRE THE UNIVERSAL BAR
 CARRIER ON THE ROOF
 CENTRAR EL PORTAEQUIPAJES
 SOBRE EL TECHO
 LASTENTRÄGER AUF DEM DACH
 ZENTRIEREN
 CENTRER LE TOIT AVEC LE
 PORTE-TOUT
 PLAATS DE UNIVERSELE DRAGER
 IN HET MIDDEN VAN HET DAK
 HELYEZZE KÖZÉPRE A RUDAKAT
 WYSRODKOWAC BAGAZNIK NA DACHU
 CENTRIRATI PRTLJAENIK NA STREHO

6

MONTAGGIO GANASCINE

HOW TO ASSEMBLE THE CLAMPS
 COMO MONTAR LAS FIJACIONES
 ZUSAMMENBAU DER
 SPANNBACKEN
 MONTAGE CROCHET
 MONTAGE VAN DE KLEMMEN
 RÖGZÍTŐ FÜLEK
 MONTAZ SZCZEK MOCUJACYCH
 MONTAÆA NAPENJALNIKA

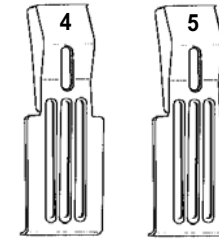

ANTERIORE	POSTERIORE
FRONT	REAR
DELANTERO	TRASERO
VORDERE	HINTERE
AVANT	ARRIERE
VOORSTE G.	ACHTERSTE G.
ELSŐ RÚD	HÁTSÓ RÚD
PRZOD	TYL
SPREDAJ	ZADAJ

	N°	N°
KIA RIO I 5P. (99-04)	4	5
KIA RIO II 5P. (05-11)	4	5
NISSAN NOTE (06-13)	4	5

7

MODELLI SENZA PREDISPOSIZIONE DELLA CASA AUTO:

CARS WITHOUT PRE-EXISTING FIXING POINT
 PARA COCHES SIN PREDISPOSICION DEL FABRICANTE
 AUTOS OHNE VOM HERSTELLER VORGESEHENE BEFESTIGUNGSPUNKTE
 VOITURES SANS POINTS DE FIXAGE PRÉVUS PAR LE CONSTRUCTEUR
 AUTO'S ZONDER DOOR DE FABRIKANT VOORZIENE BEVESTIGINGSPUNTEN
 FELHELYEZES GYÁRI JELÖLÉS NÉLKÜLI AUTÓKRA
 SAMOCHODY BEZ PRZEWIDZIANYCH PUNKTOW UMOCOWANIA
 MODELI Z NEPREDVIDENIM LEÆI»EM S STRANI PROIZVAJALCA

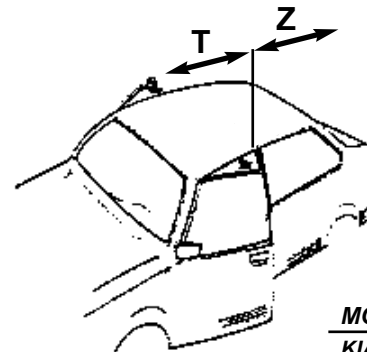

ANTERIORE	POSTERIORE
FRONT	REAR
DELANTERO	TRASERO
VORDERE	HINTERE
AVANT	ARRIERE
VOORSTE G.	ACHTERSTE G.
ELSŐ RÚD	HÁTSÓ RÚD
PRZOD	TYL
SPREDAJ	ZADAJ

MODELLI AUTO	T	Z
KIA RIO I 5P. (99-04)	250 mm.	450 mm.
KIA RIO II 5P. (05-11)	250 mm.	450 mm.
NISSAN NOTE (06-13)	200 mm.	500 mm.