

8

AVVITARE

TO SCREW
APRETAR
FESTSCHRAUBEN
VISSER
VASTSCHROEVEN
MEGHÚZNI
WKRECIC
PRIVITI

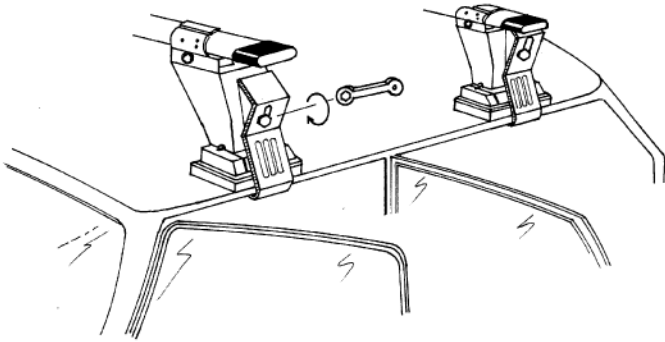

9

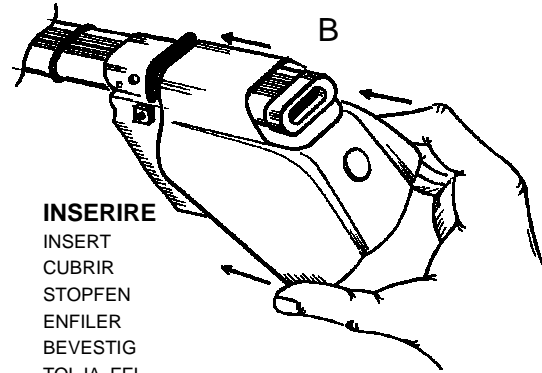
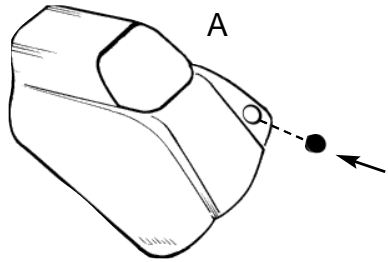
OPTIONAL**INSERIRE**

INSERT
CUBRIR
STOPFEN
ENFILER
BEVESTIG
TOLJA FEL
NALOZIC
VSTAVITI

10

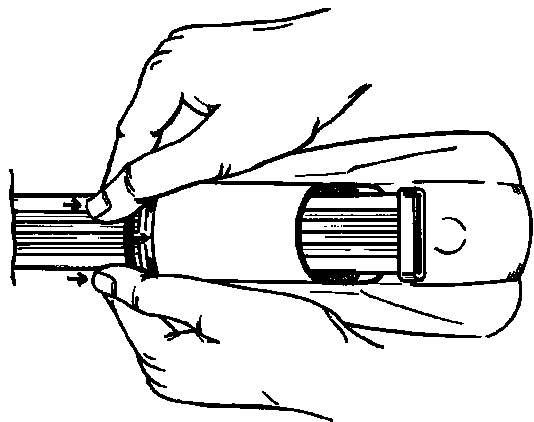
**43co**

ISTRUZIONI DI MONTAGGIO - FITTING INSTRUCTIONS - INSTRUCCIONES PARA SU MONTAJE -
MONTAGEANWEISUNGEN - INSTRUCTIONS DE MONTAGE - MONTAGE INSTRUCTIES -
SZERELÉSI UTASÍTÁS - INSTRUKCJA MONTAŻU - NAVODILA O MONTAŽI

“LOGICO”

1

**MISURE PRECISE**

EXACT DIMENSIONS
MEDIDAS CORRECTAS
GENAUE MASSE
MESURES EXACTES
EXACTE AFMETINGEN
PONTOS MÉRET
DOKLADNE WYMIARY
TO»NE MERE

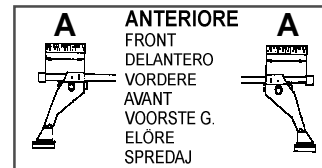
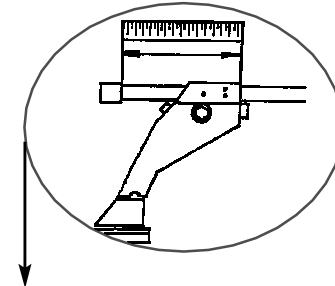

A
ANTERIORE
FRONT
DELANTERO
VORDERE
AVANT
VOORSTE G.
ELŐRE
SPREDAJ

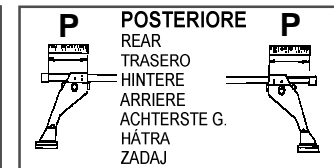

P
POSTERIORE
REAR
TRASERO
HINTERE
ARRIERE
ÄCHTERSTE G.
HÁTRA
ZADAJ

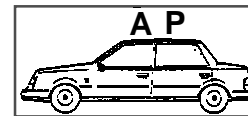

A
ANTERIORE
FRONT
DELANTERO
VORDERE
AVANT
VOORSTE G.
ELSŐ RÚD
PRZOD
SPREDAJ

P
POSTERIORE
REAR
TRASERO
HINTERE
ARRIERE
ÄCHTERSTE G.
HÁTSÓ RÚD
TYL
ZADAJ

HYUNDAI ATOS	107 mm.	115 mm.
TOYOTA AVENSIS VERSO (02)	119 mm.	120 mm.

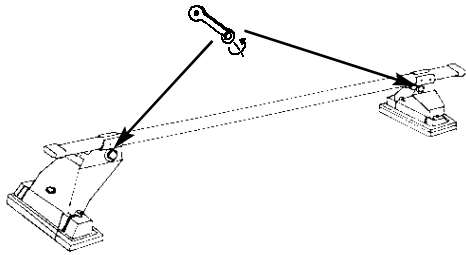
2**AVVITARE (A FONDO)**

TO SCREW (DOWN)
 APRETAR (A FONDO)
 FESTSCHRAUBEN
 VISSER (À FOND)
 VASTSCHROEVEN
 MEGHÚZNI
 WKRECIC DO KONCA
 PRIVITI (DO KONCA)

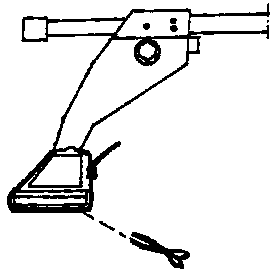
3**TAGLIARE**

TO CUT
 CORTAR
 SCHNEIDEN
 COUPER
 SNIJDEN
 ELVÁGNI
 OBCIAC
 ODREZATI

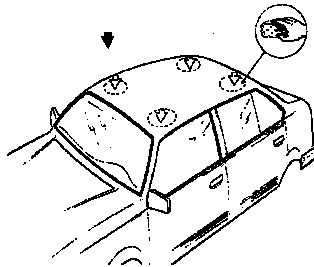
4**PULIRE IL TETTO**

CLEAN THE ROOF
 LIMPIAR EL TECHO
 DACH REINIGEN
 NETTOYER LE TOIT
 DAK SCHOONMAKEN
 TISZTÍTSÁ MEG A TETŐT
 WYCZYSCIC DACH
 O»ISTITI STREHO

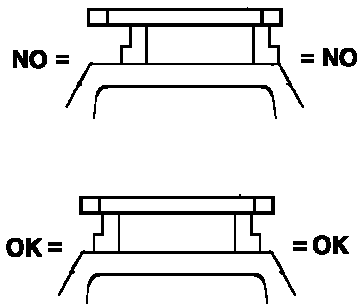
5**CENTRARE IL P. TUTTO SUL TETTO**

CENTRE THE UNIVERSAL BAR
 CARRIER ON THE ROOF
 CENTRAR EL PORTAEQUIPAJES
 SOBRE EL TECHO
 LASTENTRÁGER AUF DEM DACH
 ZENTRIEREN
 CENTRER LE TOIT AVEC LE
 PORTE-TOUIT
 PLAATS DE UNIVERSELE DRAGER
 IN HET MIDDEN VAN HET DAK
 HELYEZZE KÖZÉPRE A RUDAKAT
 WYSRODKOWAC BAGAZNIK NA DACHU
 CENTRIRATI PRTLJA»ENIK NA STREHO

6**MODELLI SENZA PREDISPOSIZIONE DELLA CASA AUTO:**

CARS WITHOUT PRE-EXISTING FIXING POINT
 PARA COCHES SIN PREDISPOSICION DEL FABRICANTE
 AUTOS OHNE VOM HERSTELLER VORGESEHENE BEFESTIGUNGSPUNKTE
 VOITURES SANS POINTS DE FIXAGE PRÉVUS PAR LE CONSTRUCTEUR
 AUTO'S ZONDER DOOR DE FABRIKANT VOORZIENE BEVESTIGINGSPUNTEN
 FELHELYEZES GYÁRI JELÖLÉS NÉLKÜLI AUTÓKRA
 SAMOCHODY BEZ PRZEWIDZIANYCH PUNKTOW UMOCOWANIA
 MODELI Z NEPREDVIDENIM LE»EI»EM S STRANI PROIZVAJALCA

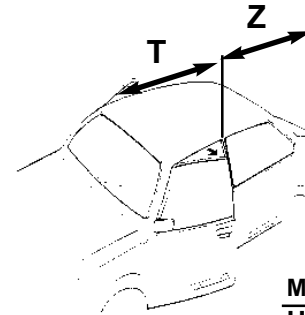

MODELLI AUTO
HYUNDAI ATOS

ANTERIORE

FRONT
 DELANTERO
 VORDERE
 AVANT
 VOORSTE G.
 ELSŐ RÚD
 PRZOD
 SPREDAJ

POSTERIORE

REAR
 TRASERO
 HINTERE
 ARRIERE
 ACHTERSTE G.
 HÁTSÓ RÚD
 TYL
 ZADAJ

T
200 mm.

Z
500 mm.

7**MODELLI CON PREDISPOSIZIONE DELLA CASA AUTO:**

CARS WITH PRE-EXISTING FIXING POINT FROM MANUFACTURER
 MODELOS CON PREDISPOSICION DEL FABRICANTE
 AUTOS MIT VOM HERSTELLER VORGESEHENE BEFESTIGUNGSPUNKTE
 VOITURES AVEC POINTS DE FIXAGE PRÉVUS PAR LE CONSTRUCTEUR
 AUTO'S MET DOOR DE FABRIKANT VOORZIENE MONTAGEPUNTEN
 FELHELYEZÉS GYÁRTÓ ÁLTAL KIJELÖLT PONTRA
 SAMOCHODY Z PRZEWIDZIANYMI PUNKTAMI UMOCOWANIA
 MODELI Z PREDVIDENIM LE»EI»EM S STRANI PROIZVAJALCA

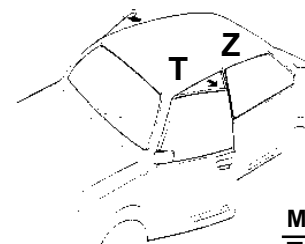

MODELLI AUTO
TOYOTA AVENSIS VERSO (02)

ANTERIORE

FRONT
 DELANTERO
 VORDERE
 AVANT
 VOORSTE G.
 ELSŐ RÚD
 PRZOD
 SPREDAJ

POSTERIORE

REAR
 TRASERO
 HINTERE
 ARRIERE
 ACHTERSTE G.
 HÁTSÓ RÚD
 TYL
 ZADAJ

T
T

Z
Z