

9

**AVVITARE**

TO SCREW  
 APRETAR  
 FESTSCHRAUBEN  
 VISSER  
 VASTSCHROEVEN  
 MEGHÚZNI  
 WKRECIC  
 PRIVITI

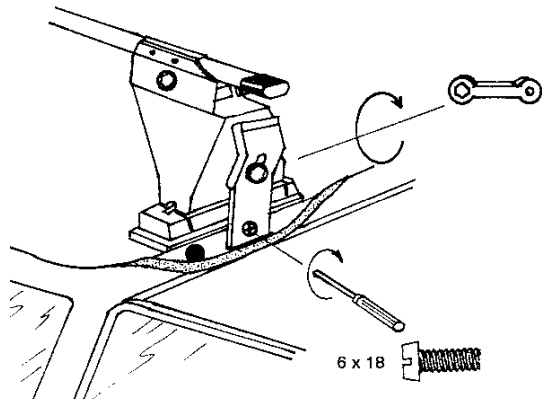

10

**OPTIONAL**

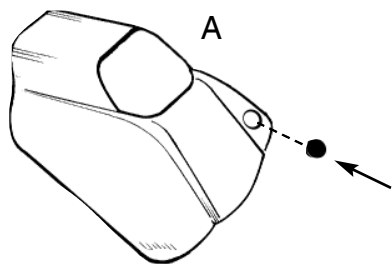

**INSERIRE**

INSERT  
 CUBRIR  
 STOPFEN  
 ENFILER  
 BEVESTIG  
 TOLJA FEL  
 NALOZIC  
 VSTAVITI

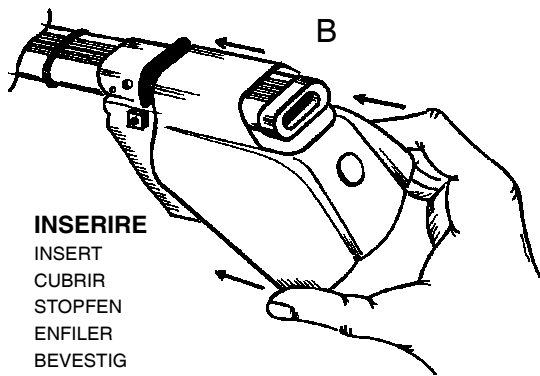

11

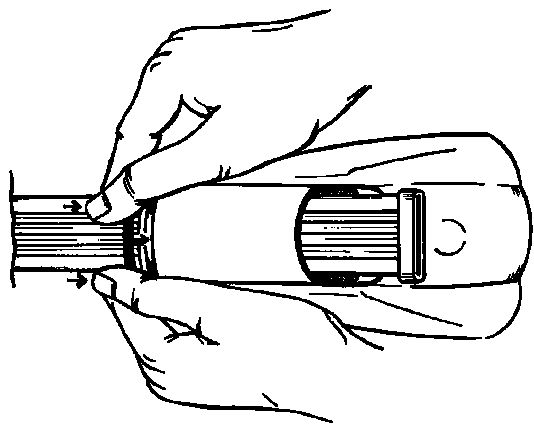

**41co**

ISTRUZIONI DI MONTAGGIO - FITTING INSTRUCTIONS - INSTRUCCIONES PARA SU MONTAJE -  
 MONTAGEANWEISUNGEN - INSTRUCTIONS DE MONTAGE - MONTAGE INSTRUCTIES -  
 SZERELÉSI UTASÍTÁS - INSTRUKCJA MONTAŻU - NAVODILA O MONTAŽI

**“LOGICO”**

1



**MISURE PRECISE**

EXACT DIMENSIONS  
 MEDIDAS CORRECTAS  
 GENAUE MASSE  
 MESURES EXACTES  
 EXACTE AFMETINGEN  
 PONTOS MÉRET  
 DOKLADNE WYMIARY  
 TO»NE MERE

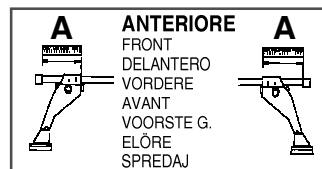
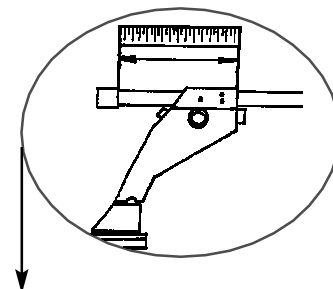

**A ANTERIORE**  
 FRONT  
 DELANTERO  
 VORDERE  
 AVANT  
 VOORSTE G.  
 ELŐRE  
 SPREDAJ

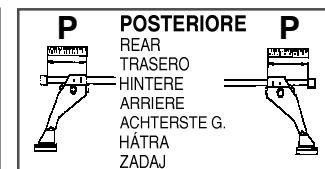

**P POSTERIORE**  
 REAR  
 TRASERO  
 HINTERE  
 ARRIERE  
 ACHTERSTE G.  
 HÁTRA  
 ZADAJ

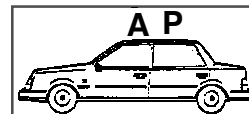

**A ANTERIORE**  
 FRONT  
 DELANTERO  
 VORDERE  
 AVANT  
 VOORSTE G.  
 ELSŐ RÚD  
 PRZOD  
 SPREDAJ

**P POSTERIORE**  
 REAR  
 TRASERO  
 HINTERE  
 ARRIERE  
 ACHTERSTE G.  
 HÁTSÓ RÚD  
 TYL  
 ZADAJ

FORD FOCUS 3P (->04)

90 mm.

104 mm.

2

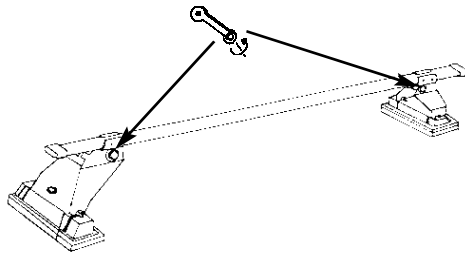

**AVVITARE (A FONDO)**

TO SCREW (DOWN)  
 APRETAR (A FONDO)  
 FESTSCHRAUBEN  
 VISSER (À FOND)  
 VASTSCHROEVEN  
 MEGHÚZNI  
 WKRECIC DO KONCA  
 PRIVITI (DO KONCA)

3

**TAGLIARE**

TO CUT  
 CORTAR  
 SCHNEIDEN  
 COUPER  
 SNIJDEN  
 ELVÁGNI  
 OBCIAC  
 ODREZATI

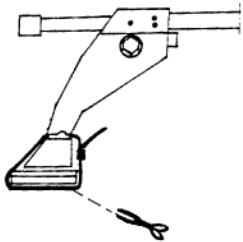

4

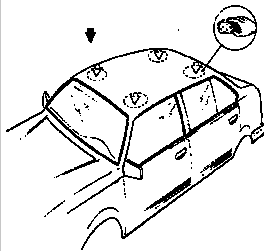

**PULIRE IL TETTO**

CLEAN THE ROOF  
 LIMPIAR EL TECHO  
 DACH REINIGEN  
 NETTOYER LE TOIT  
 DAK SCHOONMAKEN  
 TISZTÍTSA MEG A TETŐT  
 WYCZYSCIC DACH  
 O»ISTITI STREHO

5

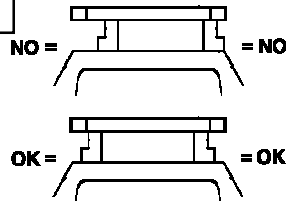

**CENTRARE IL P. TUTTO SUL TETTO**

CENTRE THE UNIVERSAL BAR  
 CARRIER ON THE ROOF

CENTRAR EL PORTAEQUIPAJES  
 SOBRE EL TECHO

LASTENTRÄGER AUF DEM DACH  
 ZENTRIEREN

CENTRER LE TOIT AVEC LE  
 PORTE-TOUT

PLAATS DE UNIVERSELE DRAGER  
 IN HET MIDDEN VAN HET DAK

HELYEZZE KÖZÉPRE A RUDAKAT

WYSRODKOWAC BAGAŻNIK NA DACHU

CENTRIRATI PRTLJAÆENIK NA STREHO

6

**MODELLI AUTO**

CARS  
 COCHES  
 WAGEN  
 VOITURES  
 AUTO  
 AUTÓ TIPUS  
 MODELI AVTOMOBILOV

**MONTAGGIO GANASCINE**

HOW TO ASSEMBLE THE CLAMPS  
 COMO MONTAR LAS FIJACIONES  
 ZUSAMMENBAU DER  
 SPANNBACKEN  
 MONTAGE CROCHET  
 MONTAGE VAN DE KLEMMEN  
 RÖGZITŐ FÜLEK  
 MONTAZ SZCZEK MOCUJACYCH  
 MONTAÆEA NAPENJALNIKA

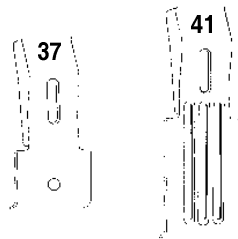

ANTERIORE	POSTERIORE
FRONT	REAR
DELANTERO	TRASERO
VORDERE	HINTERE
AVANT	ARRIERE
VOORSTE G.	ACHTERSTE G.
ELSŐ RÚD	HÁTSÓ RÚD
PRZOD	TYL
SPREDAJ	ZADAJ

	N°	N°
<b>FORD FOCUS 3P (-&gt;04)</b>	<b>37</b>	<b>41</b>

7

**MODELLI CON PREDISPOSIZIONE DELLA CASA AUTO:**

CARS WITH PRE-EXISTING FIXING POINT FROM MANUFACTURER  
 MODELOS CON PREDISPOSICION DEL FABRICANTE  
 AUTOS MIT VOM HERSTELLER VORGESEHENE BEFESTIGUNGSPUNKTE  
 VOITURES AVEC POINTS DE FIXAGE PREVUS PAR LE CONSTRUCTEUR  
 AUTO'S MET DOOR DE FABRIKANT VOORZIENE MONTAGEPUNTEN  
 FELHELYEZÉS GYÁRTÓ ÁLTAL KIJELÖLT PONTRA  
 SAMOCHODY Z PRZEWIDZIANYMI PUNKTAMI UMOCOWANIA  
 MODELI Z PREDVIDENIM LEÆI©»EM S STRANI PROIZVAJALCA

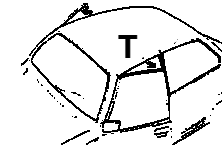

**ANTERIORE**

FRONT  
 DELANTERO  
 VORDERE  
 AVANT  
 VOORSTE G.  
 ELSŐ RÚD  
 PRZOD  
 SPREDAJ

**MODELLI AUTO**

**FORD FOCUS 3 P (->04)**

**T**

**T**

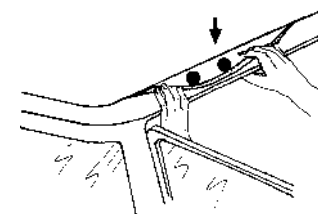

**SCALZARE LA GUARNIZIONE**

REMOVE THE GASKET  
 QUITE LA MOLDURA  
 DICHTUNG HERAUSZIEHEN  
 OTER LA GUARNITURE  
 PAKKUNG LOSMAKEN  
 KIHAJTANI A TÖMITÖGUMIT  
 WYCIAGNAC USZCZELKE  
 ODMAKNITI TESNILO

8

**MODELLI SENZA PREDISPOSIZIONE DELLA CASA AUTO:**

CARS WITHOUT PRE-EXISTING FIXING POINT  
 PARA COCHES SIN PREDISPOSICION DEL FABRICANTE  
 AUTOS OHNE VOM HERSTELLER VORGESEHENE BEFESTIGUNGSPUNKTE  
 VOITURES SANS POINTS DE FIXAGE PRÉVUS PAR LE CONSTRUCTEUR  
 AUTO'S ZONDER DOOR DE FABRIKANT VOORZIENE BEVESTIGINGSPUNTEN  
 FELHELYEZES GYÁRI JELÖLÉS NÉLKÜLI AUTÓKRA  
 SAMOCHODY BEZ PRZEWIDZIANYCH PUNKTOW UMOCOWANIA  
 MODELI Z NEPREDVIDENIM LEÆI©»EM S STRANI PROIZVAJALCA

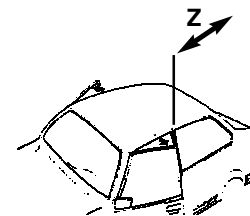

**POSTERIORE**

REAR  
 TRASERO  
 HINTERE  
 ARRIERE  
 ACHTERSTE G.  
 HÁTSÓ RÚD  
 TYL  
 ZADAJ

**MODELLI AUTO**

**FORD FOCUS 3 P (->04)**

**Z**

**150 mm.**